

MODEL 2500 & 1500

Service Manual

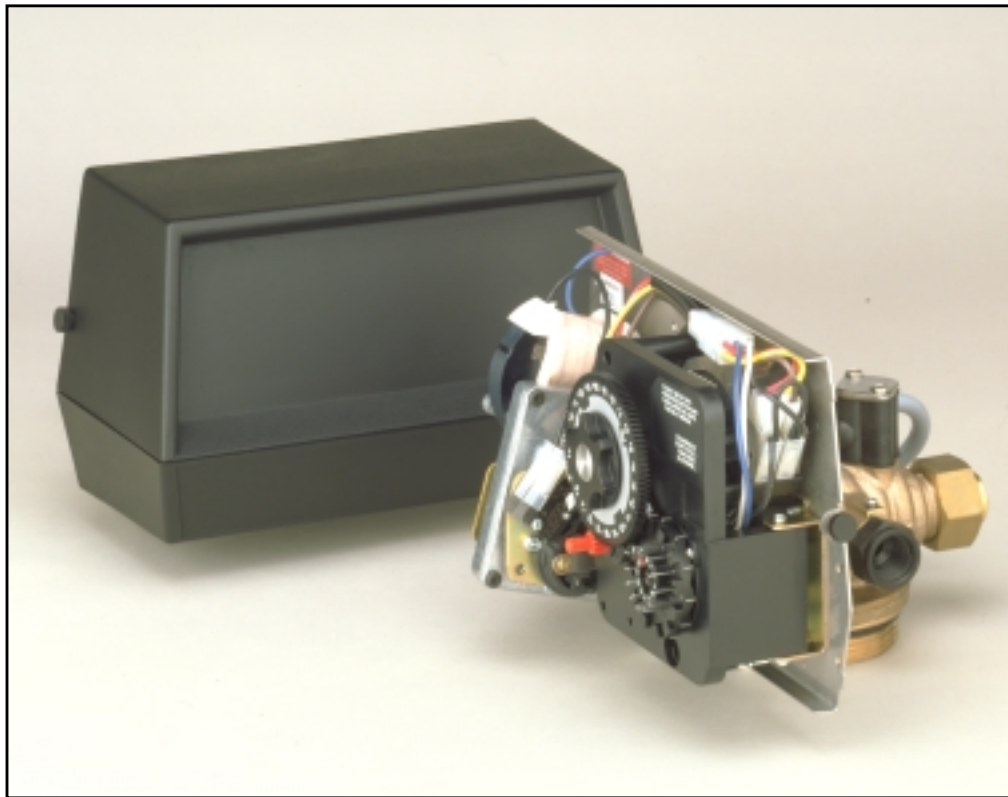

IMPORTANT: Fill in pertinent information on page 2 for future reference.

MODEL 2500 & 1500

Job Specification Sheet

* JOB NO. _____

* MODEL NO. _____

* WATER TEST _____

* CAPACITY PER UNIT _____ MAX. _____ PER REGENERATION

* MINERAL TANK SIZE DIA. _____ HEIGHT _____

* BRINE TANK SIZE &
SALT SETTING PER REGENERATION: _____

* CONTROL VALVE SPECIFICATIONS

1) Type of Timer

A) 7 day _____

B) 12 day _____

2) Regeneration Cycle

A) Separate Time Fill _____

B) Rapid Rinse _____

3) Regeneration Program Settings (see pages 6 & 7)

A) Backwash _____ min.

B) Brine & Slow Rinse _____ min.

C) Rapid Rinse _____ min.

D) Brine Tank Refill _____ min.

4) Drain Line Flow Controller _____ gpm

5) Brine Refill Rate _____

6) Injector Size _____

MODEL 2500 & 1500

Installation Instructions

The water softener should be installed with the inlet, outlet and drain connections made in accordance with manufacturer's recommendations and to meet applicable plumbing codes.

1. Remove control box cover.
2. Make "Time of Day" setting and set "Skipper Wheel." (See time control instructions.)
3. Observe regeneration cycle settings. (These are factory preset and need no adjustment.)
4. Add three inches of water to brine tank.
5. NOTE: To set the control to the various positions noted below — turn the manual regeneration knob slowly in a clockwise direction until the drive motor runs and positions the valve drive shaft (located in the lower center of the control box).

Control Valve Positions (see pages 8 and 9)

Service — Drive shaft out

Backwash — Drive shaft in

Brine and Rinse — Drive shaft 1/2 way out

Brine Tank Fill — Drive shaft out but brine cam holds brine valve stem in.

6. Run water through softener with control in service position for at least three (3) minutes to settle bed.
7. Position valve to backwash and check to make sure that drain line flow remains steady for ten (10) minutes.
8. Position valve to brine tank fill and check to see if tank is filling.
9. Position valve to brine position and check suction.
10. Position valve to start of brine tank fill cycle. Brine valve drive cam will hold valve in at this position to fill the brine tank for the first regeneration.
11. Replace control box cover.
12. Check power cord connection. (Note: Make sure control is plugged into a non-interrupted electrical circuit).
13. Put salt in brine tank. (Do not use granulated salt.)

MODEL 3200 TIMER

Timer Setting Procedure

How To Set Days On Which Water Conditioner Is To Regenerate:

Rotate the skipper wheel until the number "1" is at the red pointer. Set the days that regeneration is to occur by sliding tabs on the skipper wheel outward to expose trip fingers. Each tab is one day. Finger at red pointer is tonight. Moving clockwise from the red pointer, extend or retract fingers to obtain the desired regeneration schedule.

How To Set The Time Of Day:

Press and hold the red button in to disengage the drive gear.

Turn the large gear until the actual time of day is at the time of day pointer.

Release the red button to again engage the drive gear.

How To Manually Regenerate Your Water Conditioner At Any Time:

Turn the manual regeneration knob clockwise.

This slight movement of the manual regeneration knob engages the program wheel and starts the regeneration program.

The black center knob will make one revolution in the following approximately three hours and stop in the position shown in the drawing.

Even though it takes three hours for this center knob to complete one revolution, the regeneration cycle of your unit might be set only one half of this time.

In any event, conditioned water may be drawn after rinse water stops flowing from the water conditioner drain line.

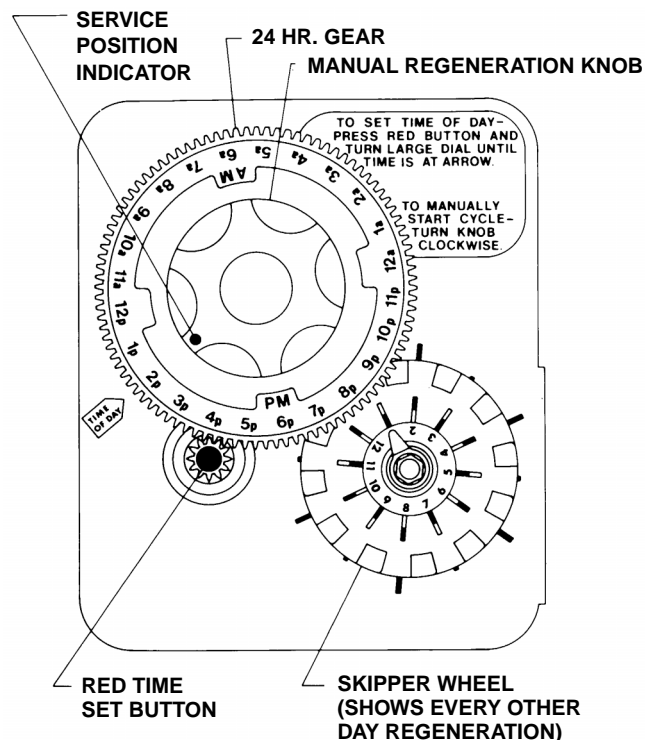

IMPORTANT!

SALT LEVEL MUST ALWAYS BE ABOVE WATER LEVEL IN BRINE TANK.

MODEL 3200 TIMER

Regeneration Cycle Program Setting Procedure

(Rapid Rinse) White Drive Cam and Brine Valve Cam

How to Set The Regeneration Cycle Program:

The regeneration cycle program on your water conditioner has been factory preset, however, portions of the cycle or program may be lengthened or shortened in time to suit local conditions.

To expose cycle program wheel, grasp timer in upper left-hand corner and pull, releasing snap retainer and swinging timer to the right.

To change the regeneration cycle program, the program wheel must be removed. Grasp program wheel and squeeze protruding lugs towards center, lift program wheel off timer. (Switch arms may require movement to facilitate removal.)

How To Change The Length Of The Backwash Time:

The program wheel as shown in the drawing is in the service position. As you look at the numbered side of the program wheel, the group of pins starting at zero determines the length of time your unit will backwash.

FOR EXAMPLE: If there are six pins in this section, the time of backwash will be 12 min. (2 min. per pin). To change the length of backwash time, add or remove pins as required. The number of pins times two equals the backwash time in minutes. **(Note: Do not add pins before "0" minutes designation.)**

How To Change The Length Of Brine And Rinse Time:

The group of holes between the last pin in the backwash section and the second group of pins determines the length of time that your unit will brine and rinse. (2 min. per hole.)

To change the length of brine and rinse time, move the rapid rinse group of pins to give more or fewer holes in the brine and rinse section. Number of holes times two equals brine and rinse time in minutes.

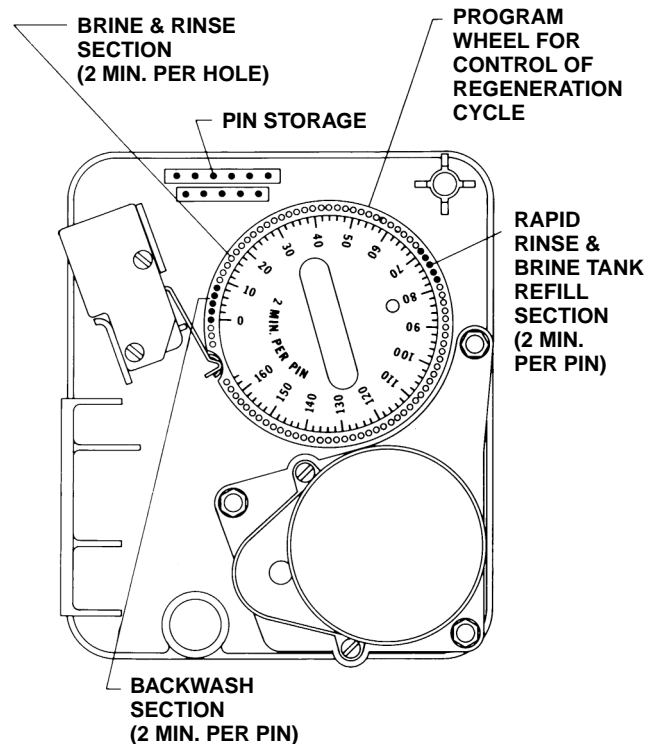

How To Change The Length Of Rapid Rinse And Brine Tank Fill Time:

The second group of pins on the program wheel determines the length of time that your water conditioner will rapid rinse and brine tank fill. (2 min. per pin.)

To change the length of rapid rinse and brine tank fill time, add or remove pins at the higher numbered end of this section as required. The number of pins times two equals the rapid rinse and brine tank fill time in minutes.

The regeneration cycle is complete when the outer micro-switch drops off the last pin in the rapid rinse and brine tank fill group of pins. The program wheel, however, will continue to rotate until the inner micro-switch drops into the notch on the program wheel.

Return timer to closed position engaging snap retainer in back plate. Make certain all electrical wires locate above snap retainer post.

IMPORTANT!
SALT LEVEL MUST ALWAYS BE ABOVE WATER LEVEL IN BRINE TANK.

MODEL 3200 TIMER

Regeneration Cycle Program Setting Procedure

(Brine Tank Refill Separate From Rapid Rinse — STF) Black Drive Cam and Brine Valve Cam

How to Set The Regeneration Cycle Program:

The regeneration cycle program on your water conditioner has been factory preset, however, portions of the cycle or program may be lengthened or shortened in time to suit local conditions.

To expose cycle program wheel, grasp timer in upper left-hand corner and pull, releasing snap retainer and swinging timer to the right.

To change the regeneration cycle program, the program wheel must be removed. Grasp program wheel and squeeze protruding lugs towards center, lift program wheel off timer. (Switch arms may require movement to facilitate removal.)

How To Change The Length Of The Backwash Time:

The program wheel as shown in the drawing is in the service position. As you look at the numbered side of the program wheel, the group of pins starting at zero determines the length of time your unit will backwash.

FOR EXAMPLE: If there are six pins in this section, the time of backwash will be 12 min. (2 min. per pin). To change the length of backwash time, add or remove pins as required. The number of pins times two equals the backwash time in minutes. **(Note: Do not add pins before "0" minutes designation.)**

How To Change The Length Of Brine And Rinse Time:

The group of holes between the last pin in the backwash section and the second group of pins determines the length of time that your unit will brine and rinse. (2 min. per hole.)

To change the length of brine and rinse time, move the rapid rinse group of pins to give more or fewer holes in the brine and rinse section. Number of holes times two equals brine and rinse time in minutes.

How To Change The Length Of Rapid Rinse:

The second group of pins on the program wheel determines the length of time that your water conditioner will rapid rinse. (2 min. per pin.)

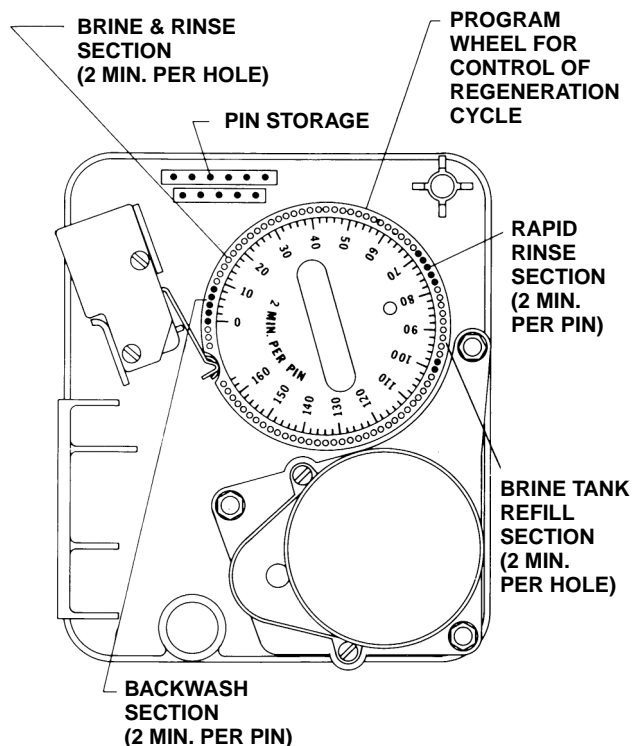

To change the length of rapid rinse time, add or remove pins at the higher numbered end of this section as required. The number of pins times two equals the rapid rinse time in minutes.

How To Change The Length Of Brine Tank Refill Time:

The second group of holes on the program wheel determines the length of time that your water conditioner will refill the brine tank. (2 min. per hole.)

To change the length of refill time, move the two pins at the end of the second group of holes as required.

The regeneration cycle is complete when the outer micro-switch is tripped by the two pin set at end of the brine tank refill section. The program wheel, however, will continue to rotate until the inner micro-switch drops into the notch on the program wheel.

Return timer to closed position engaging snap retainer in back plate. Make certain all electrical wires locate above snap retainer post.

IMPORTANT!

SALT LEVEL MUST ALWAYS BE ABOVE WATER LEVEL IN BRINE TANK.

MODEL 2500 & 1500

Water Conditioner Flow Diagrams

1. SERVICE POSITION

Hard water enters unit at valve inlet and flows down thru the mineral in the mineral tank. Conditioned water enters center tube thru the bottom distributor — then flows up thru the center tube — around the piston and out the top outlet of the valve.

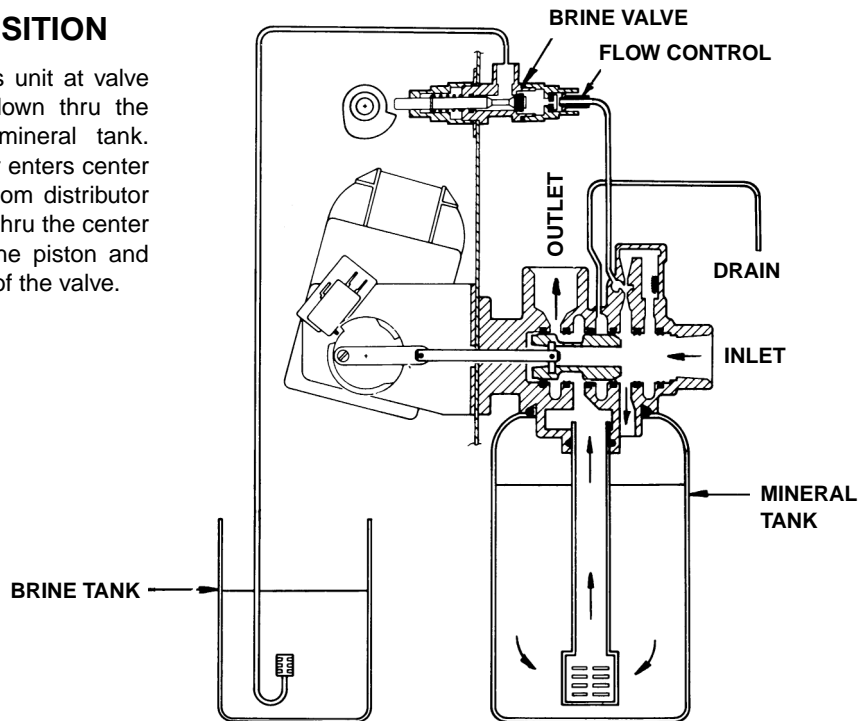

2. BACKWASH POSITION

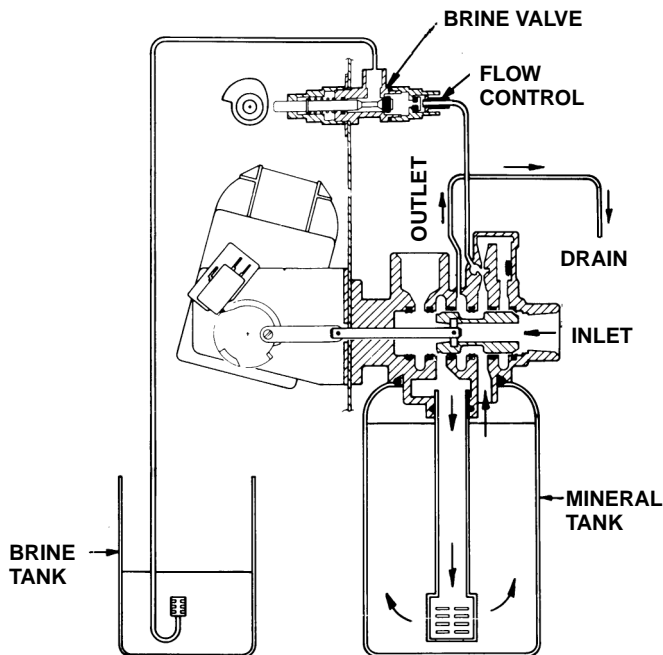

Hard water enters unit at valve inlet — flows thru piston — down center tube — thru bottom distributor and up thru the mineral — around the piston and out the drain line.

3. BRINE POSITION

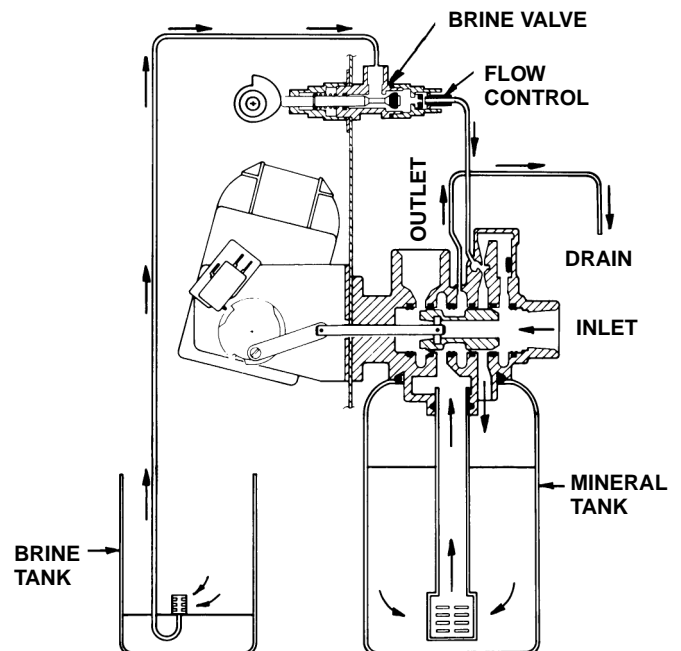

Hard water enters unit at valve inlet — flows up into injector housing and down thru nozzle and orifice to draw brine from the brine tank — brine flows down thru mineral and enters the center tube thru bottom distributor — flows up thru center tube — around the piston and out thru the drain line.

MODEL 2500 & 1500

Water Conditioner Flow Diagrams (Cont'd.)

4. SLOW RINSE POSITION

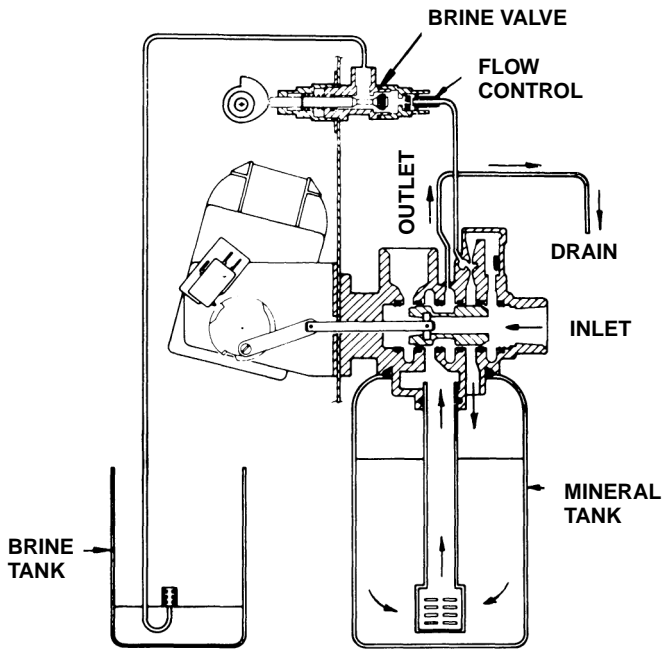

Hard water enters unit at valve inlet — flows up into injector housing and down thru nozzle and orifice — around the piston — down thru mineral — enters center tube thru center tube — around piston and out thru drain line.

5. RAPID RINSE & BRINE TANK FILL

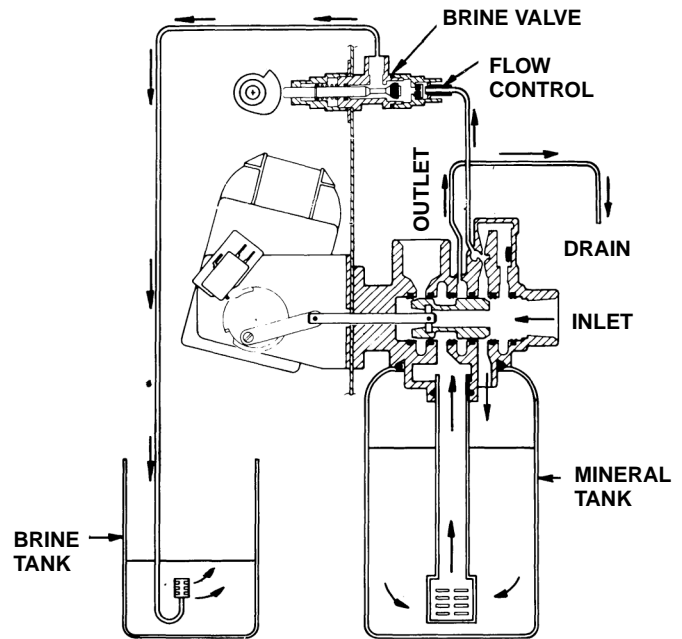

Hard water enters unit at valve inlet — flows up thru injector housing and thru brine valve to fill brine tank — hard water also flows directly from inlet down thru mineral into center tube bottom distributor and up thru center tube — around piston and out thru the drain line.

FOR SEPARATE TIME FILL ONLY

6. RAPID RINSE

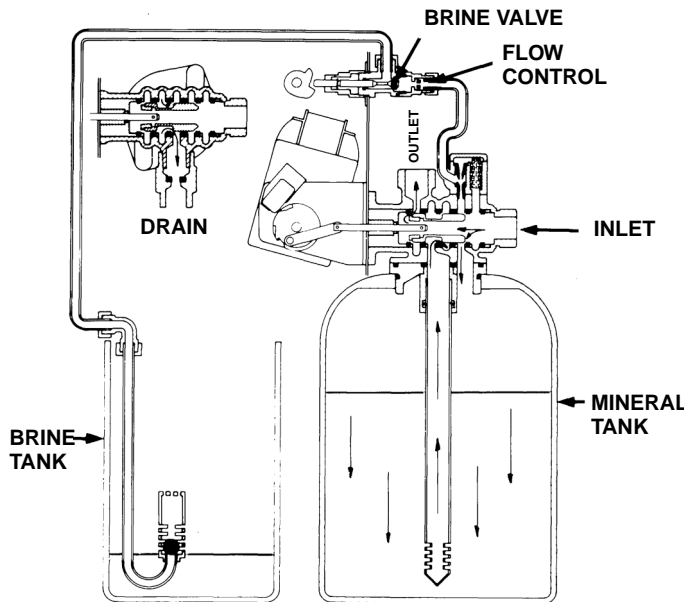

Hard water enters unit at valve inlet — flows up thru injector housing and thru brine valve to fill brine tank hard water also flows directly from inlet down thru mineral into center tube bottom distributor and up thru center tube — around piston and out thru the drain line.

7. BRINE TANK FILL POSITION

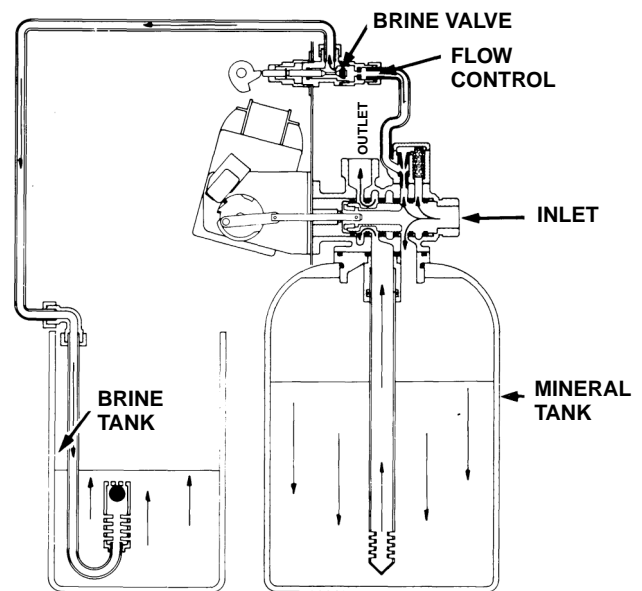

Hard water enters unit at valve inlet — flows up thru the injector housing — thru the brine valve to fill the brine tank.

Notes

MODEL 2500 & 1500

Control Valve Drive Assembly

(See opposite page for parts list)

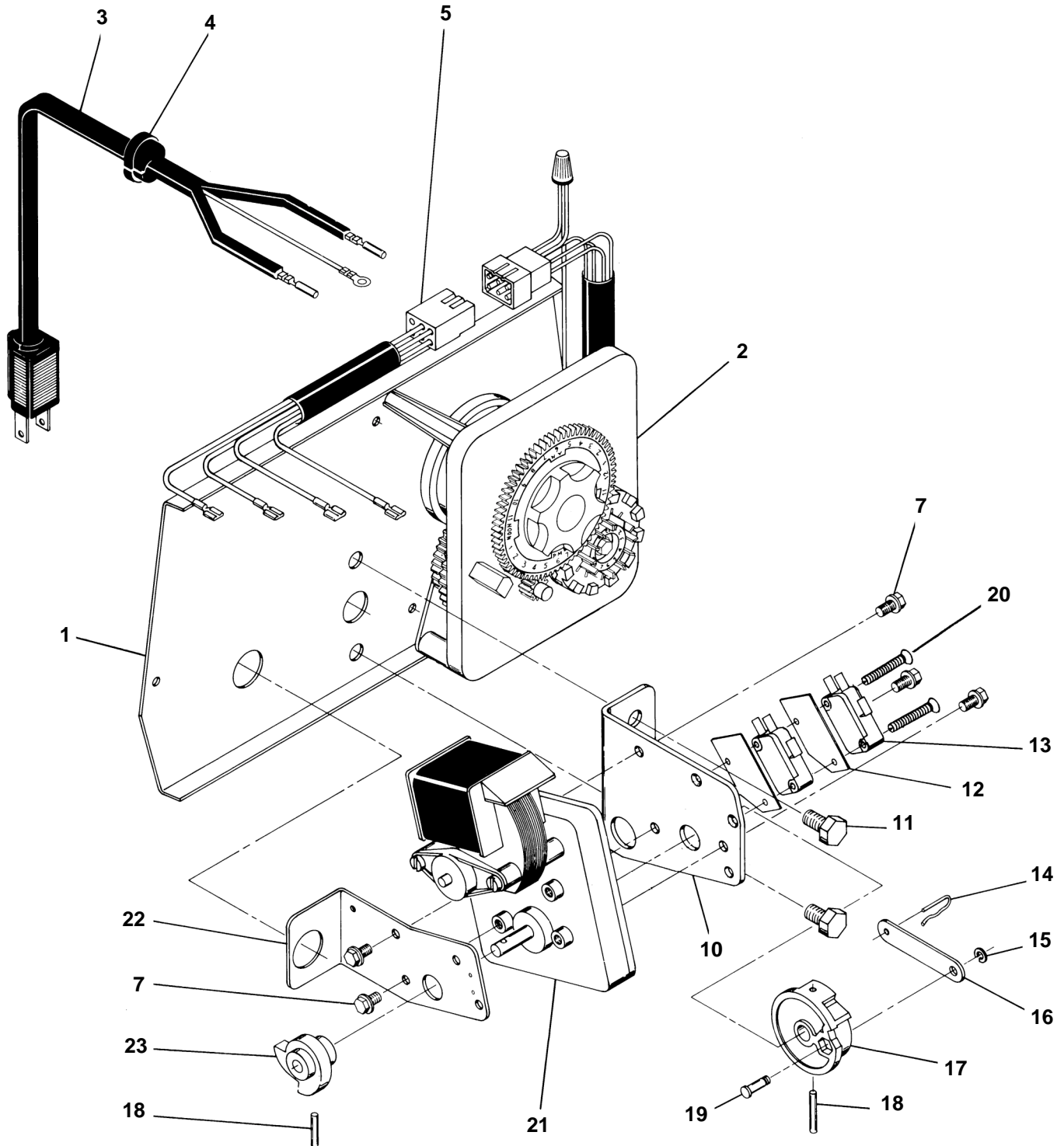

MODEL 2500 & 1500

Control Valve Drive Assembly

Parts List

Item No.	Quantity	Part No.	Description
1	1	14884	Back Plate - Stainless Steel
	1	11209	Back Plate - Slant Front (not shown)
2	1		3200, 3000 Timer 7 or 12 Day
3	1	11838	Power Cord
4	1	13547	Strain Relief
5	1	11667	Wire Harness
6			Not Assigned
7	5	10872	Screw - Motor Mounting
8			Not Assigned
9			Not Assigned
10	1	10774	Bracket - Motor Mounting
11	2	10231	Screw - Drive Mounting
12	2	10302	Insulator
13	2	10218	Switch
14	1	10909	Connecting Link Pin
15	1	10250	Retaining Ring
16	1	10621	Connecting Link
17	1	12576	Drive Cam - STE (Black)
	1	12102	Drive Cam - RR (White)
18	2	10338	Roll Pin
19	1	13366	Drive Bearing
20	2	14923	Screw - Switch Mounting
21	1	10769	Motor
22	1	11826	Bracket - Brine Valve Side
23	1	12777	Brine Valve Cam - STE (Black)
	1	10815	Brine Valve Cam - RR (White)
24	2	10300	Screw - Timer Mounting (not shown)
25	1	13741	Hole Plug (not shown)
26	1	17904	Hole Plug (not shown)

COVER MOUNTING HARDWARE

Stainless Steel

Back Plate . . . 2 19367 Screw

Slant Front

Back Plate . . . 4 10300 Screw

MODEL 2500

Control Valve Assembly

(See opposite page for parts list)

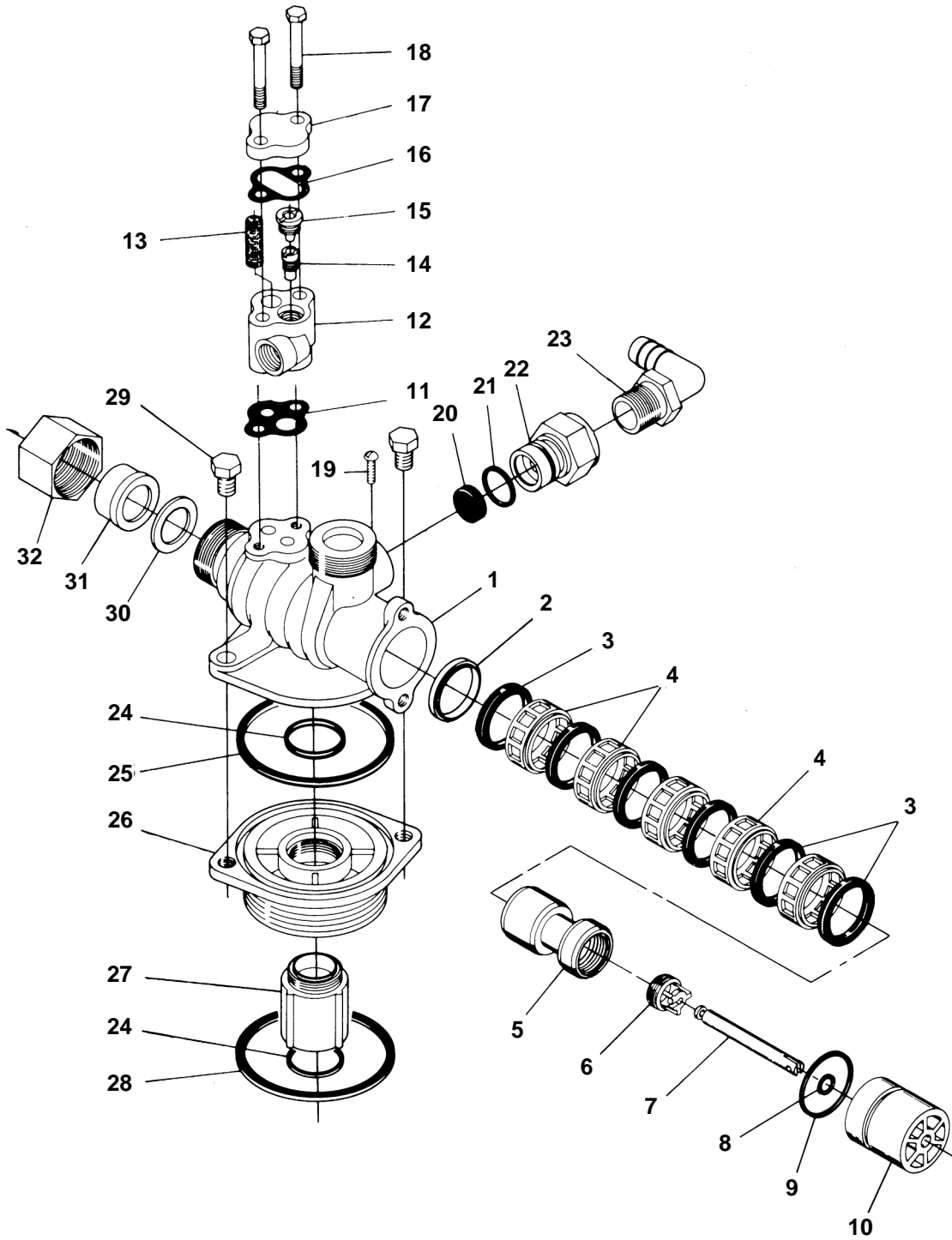

MODEL 2500

Control Valve Assembly

Parts List

Item No.	Quantity	Part No.	Description
1.	1	11212	Valve Body
2.	1	10757	End Spacer
	1	10757B	End Spacer, Hot Water
3.	6	10545	Seal Ring
4.	5	11451	Spacer
	5	16589	Spacer, Hot Water
5.	1	15168	Piston
6.	1	14309	Piston Rod Retainer
	1	16590	Piston Rod Retainer, Hot Water
7.	1	14452	Piston Rod
8.	1	10209	Seal Quad Ring
	1	10209-01	Seal Quad Ring, Hot Water
9.	1	40078	Seal O-Ring - End Plug
10.	1	10598	End Plug Assembly
	1	10598-01	End Plug Assembly, Hot Water
11.	1	11475	Injector Body Gasket
12.	1	17776	Injector Body - Plastic
	1	11483	Injector Body - Brass
13.	1	10227	Injector Screen
14.	1	10914	Injector Throat (Specify Size)
	1	10226	Injector Throat, Stainless Steel (Specify Size)
15.	1	10913	Injector Nozzle (Specify Size)
	1	10225	Injector Nozzle, Stainless Steel (Specify Size)
16.	1	10229	Injector Cover Gasket
17.	1	10228	Injector Cover (Brass Body)
	1	11893	Injector Cover (Plastic Body)
18.	1	10692	Injector Body Screw
19.	1	11180	Flow Control Retainer Screw
20.	1		Flow Control Washer (Specify Flow Rate in G.P.M.)
21.	1	11183	Seal O-Ring
22.	1	11385	Flow Control Housing
	1	11385-03	Flow Control Housing, Brass
	1	11385-13	Flow Control Housing, Brass Bored
23.	1	12338	1/2 Pipe x 1/2 Hose x 90° Drain Fitting
24.	2	10244	Inside Tube O-Ring
25.	1	11208	Seal O-Ring
26.	1	11143	Valve Body Adapter (For 2-1/4 - 16 Thd)
	1	12341	Valve Body Adapter (For 1/2 - 8 Thd)
27.	1	11966	Distributor Tube Pilot Assembly 13/16"
	1	14673	Distributor Tube Pilot Assembly 13/16", Hot Water
28.	1	10207	Tank O-Ring (For 2-1/4 - 16 Thd)
	1	10381	Tank O-Ring (For 2-1/2 - 8 Thd)
	1	12570	Tank O-Ring (Park)
29.	2	11224	Hex Head Cap Screw
30.	2	11206	Fitting Gasket
31.	2	11205	Tube Fitting Special
32.	2	11207	Special Nut
NOTE: For Flat Cap/Backwash Filter Valve — Less Items 12 thru 18.			
33.	1	11893	Cap
34.	2	15137	Screw Flat Cap

MODEL 1500 & 1500 SM

Control Valve Assembly

(See opposite page for parts list)

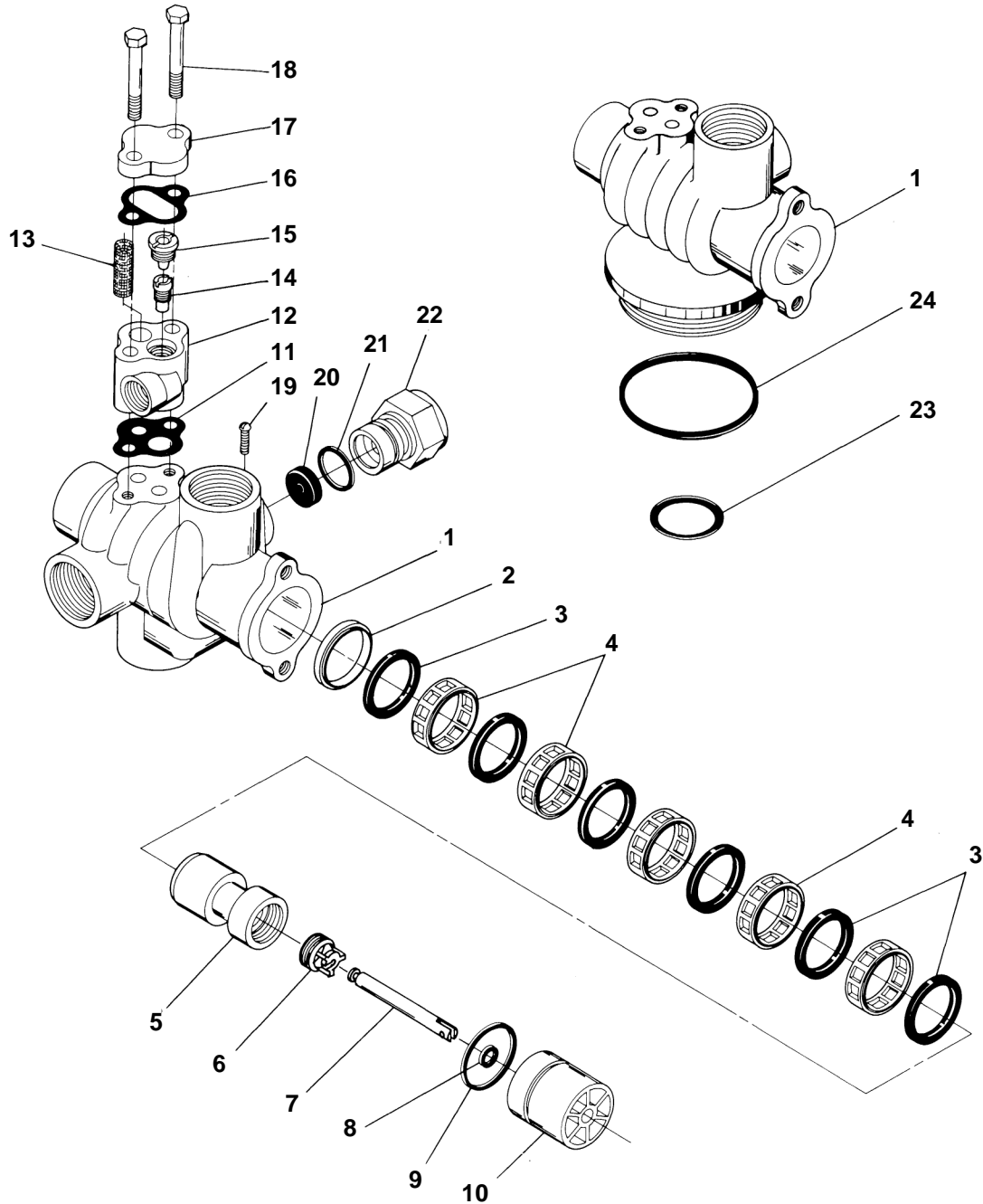

MODEL 1500 & 1500 SM

Control Valve Assembly

Parts List

Item No.	Quantity	Part No.	Description
1	1	10729	Valve Body - Side Mount
	1	10680	Valve Body - Top Mtg. (2-1/2 - 8 Thd)
2	1	10757	End Spacer
	1	10757B	End Spacer, Hot Water
3	6	10545	Seal Ring
	6	17773	Silicone
4	5	11451	Spacer
	5	16589	Spacer, Hot Water
5	1	15168	Piston
6	1	14309	Piston Rod Retainer
	1	16590	Piston Rod Retainer, Hot Water
7	1	14452	Piston Rod
8	1	10209	Seal Quad Ring
9	1	10234	Seal O-Ring - End Plug
10	1	10598	End Plug Assembly
	1	10598-01	End Plug Assembly, Hot Water
11	1	11475	Injector Body Gasket
12	1	17776	Injector Body - Plastic
	1	11483	Injector Body - Brass
13	1	10227	Injector Screen
14	1	10914	Injector Throat (Specify Size)
	1	10226	Injector Throat, Stainless Steel (Specify Size)
15	1	10913	Injector Nozzle (Specify Size)
	1	10225	Injector Nozzle, Stainless Steel (Specify Size)
16	1	10229	Injector Cover Gasket
17	1	10228	Injector Cover (Brass Body)
	1	11893	Injector Cover (Plastic Body)
18	1	10692	Injector Body Screw
19	1	11180	Flow Control Retainer Screw
20	1		Flow Control Washer (Specify Flow Rate in G.P.M.)
21	1	11183	Seal O-Ring
22	1	11385	Flow Control Housing
	1	11385-03	Flow Control Housing, Brass
	1	11385-13	Flow Control Housing, Brass Bored
23	1	10244	Inside Tube O-Ring
24	1	12570	Tank O-Ring (Park)
NOTE: For Flat Cap/Backwash Filter Valve Less Items 12 thru 18.			
25	1	11893	Flat Cap (not shown)
26	2	15137	Screw Flat Cap (not shown)

MODEL 3200 TIMER

Timer Assembly

(See opposite page for parts list)

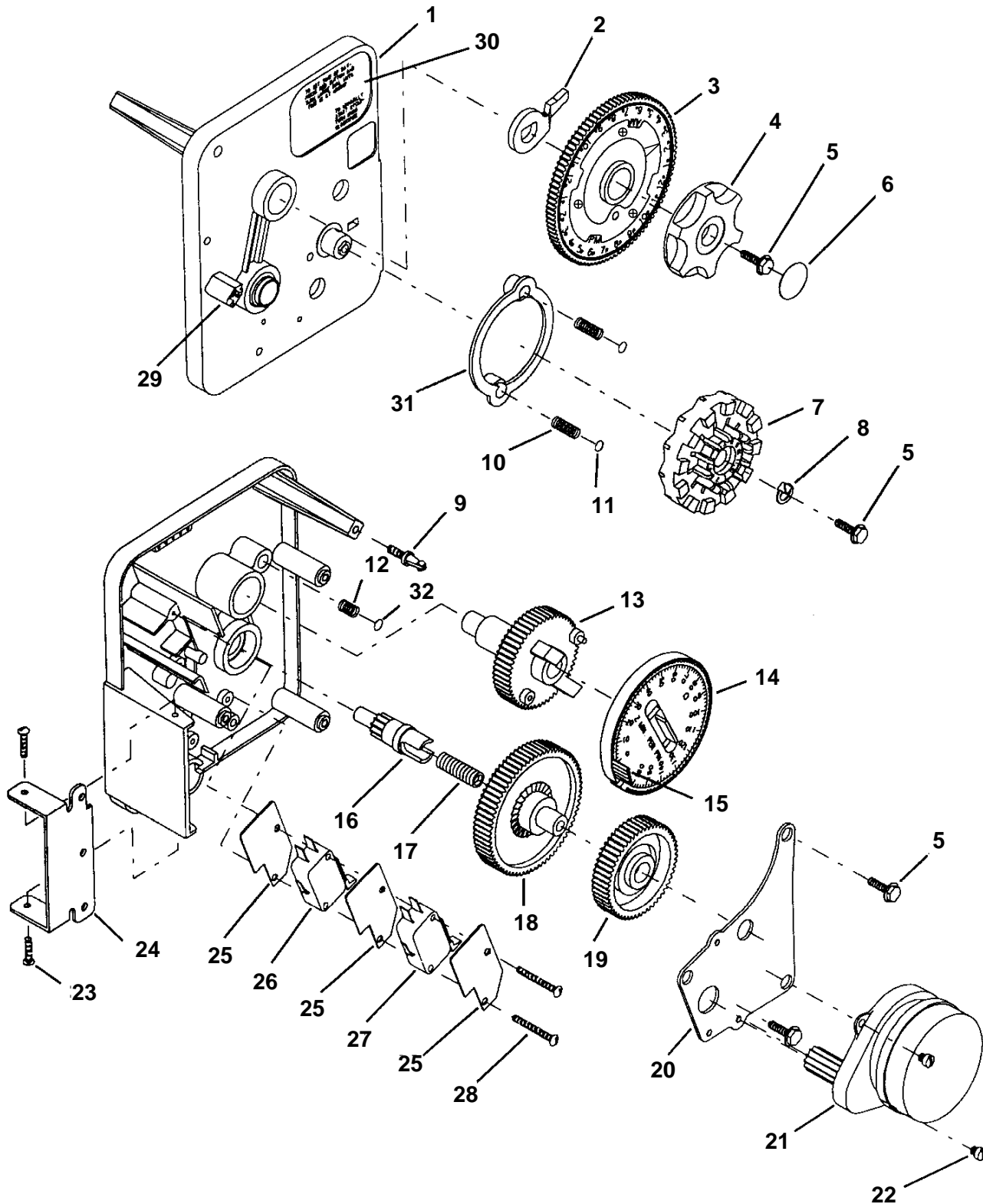

MODEL 3200 TIMER

Timer Assembly

Parts List

Item No.	Quantity	Part No.	Description
1	1	13870	Timer Housing
2	1	13011	Cycle Actuator Arm
3	1	40096-24	24 Hour Gear Assembly, 12 Midnight
		40096-02	24 Hour Gear Assembly, 2 a.m.
4	1	13886-01	Knob
5	5	13296	Screw - Timer Knob and Motor Mtg. Plate
6	1	11999	Button Decal
7	1	14381	Skipper Wheel Assembly - 12 Day
		14860	Skipper Wheel Assembly - 7 Day
8	1	13014	Regeneration Pointer
9	1	14265	Spring Clip
10	2	13311	Spring - Skipper Wheel Detent
11	2	13300	Ball - 1/4 in. Dia. Skipper Wheel
12	1	15424	Spring - Main Gear Detent
13	1	13911	Main Drive Gear
14	1	19210	Program Wheel
15	21	15493	Roll Pin
16	1	13018	Idler Shaft
17	1	13312	Spring - Idler
18	1	13017	Idler Gear
19	1	13164	Drive Gear
20	1	13887	Motor Mounting Plate
21	1	18743	Motor - 120V., 60 Hz.
		19659	Motor - 24V., 60 Hz.
22	2	13278	Screw - Motor Mounting
23	3	11384	Screw - Timer Hinge & Ground Wire
24	1	13881	Hinge Bracket
25	3	14087	Insulator
26	1	10896	Switch
27	1	15320	Switch
28	2	11413	Screw - Switch Mounting
29	1	14007	Decal - Time of Day
30	1	14045	Decal - Instructions
31	1	13864	Skipper Wheel Ring
32	1	15066	Ball 1/4 in. Dia. Main Gear
Not Shown.	1	13902	Harness
Not Shown.	2	12681	Wire Connector
Not Shown.	1	15354-01	Ground Wire

1600 Series Brine System Assembly

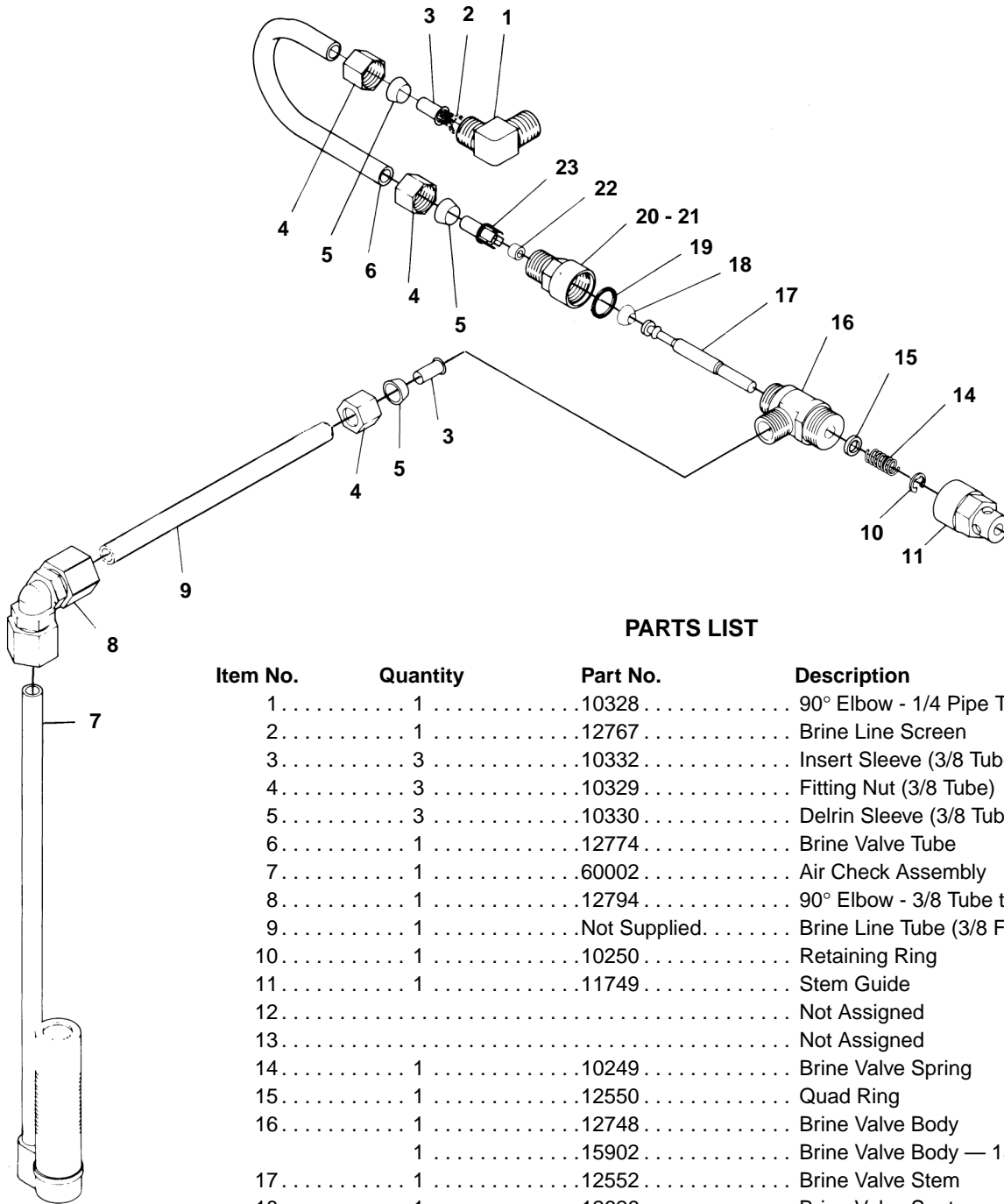

PARTS LIST

Item No.	Quantity	Part No.	Description
1	1	10328	90° Elbow - 1/4 Pipe Thd. to 3/8 Tube
2	1	12767	Brine Line Screen
3	3	10332	Insert Sleeve (3/8 Tube)
4	3	10329	Fitting Nut (3/8 Tube)
5	3	10330	Delrin Sleeve (3/8 Tube)
6	1	12774	Brine Valve Tube
7	1	60002	Air Check Assembly
8	1	12794	90° Elbow - 3/8 Tube to 3/8 Tube
9	1	Not Supplied.	Brine Line Tube (3/8 Flexible Tube)
10	1	10250	Retaining Ring
11	1	11749	Stem Guide
12			Not Assigned
13			Not Assigned
14	1	10249	Brine Valve Spring
15	1	12550	Quad Ring
16	1	12748	Brine Valve Body
	1	15902	Brine Valve Body — 1500SM
17	1	12552	Brine Valve Stem
18	1	12626	Brine Valve Seat
19	1	11982	O-Ring
*20	1	12747	Flow Control Fitting
*21	1		Flow Control Label — (Specify Flow Rate)
*22	1		Flow Control Washer — (Specify Flow Rate)
*23	1	12098	Flow Control Retainer

* These Parts Are Furnished Assembled Together As A Brine Line Flow Control (BLFC).

MODEL 2500 & 1500

Service Instructions

PROBLEM	CAUSE	CORRECTION
1. Softener fails to regenerate.	A. Electrical service to unit has been interrupted. B. Timer is defective. C. Power Failure	A. Assure permanent electrical service (check fuse, plug, pull chain or switch). B. Replace timer. C. Reset Time of Day.
2. Hard water.	A. By-pass valve is open. B. No Salt in Brine Tank. C. Injector screen plugged. D. Insufficient water flowing into brine tank. E. Hot water tank hardness. F. Leak at distributor tube. G. Internal valve leak.	A. Close by-pass valve. B. Add salt to brine tank and maintain salt level above water level. C. Clean injector screen. D. Check brine tank fill time and clean brine line flow control if plugged. E. Repeated flushing of the hot water tank is required. F. Make sure distributor tube is not cracked. Check O-Ring and tube pilot. G. Replace seals and spacers and/or piston.
3. Unit used too much salt.	A. Improper salt setting. B. Excessive water in brine Tank.	A. Check salt usage and salt setting. B. See problem no. 7.
4. Loss of water pressure.	A. Iron buildup in line to water conditioner. B. Iron buildup in water conditioner. C. Inlet of control plugged due to foreign material broken loose from pipes by recent work done on plumbing system.	A. Clean line to water conditioner. B. Clean control and add mineral cleaner to mineral bed. Increase frequency of regeneration. C. Remove piston and clean control.
5. Loss of mineral through drain line.	A. Air in water system.	A. Assure that well system has proper air eliminator control. Check for dry well condition.
6. Iron in conditioned water.	A. Fouled mineral bed.	A. Check backwash, brine draw and brine tank fill. Increase frequency of regeneration. Increase backwash time.

MODEL 2500 & 1500

Service Instructions (Cont'd.)

PROBLEM	CAUSE	CORRECTION
7. Excessive water in brine tank.	A. Plugged drain line flow control. B. Plugged injector system. C. Timer not cycling D. Foreign material in brine valve. E. Foreign material in brine line flow control.	A. Clean flow control. B. Clean injector and screen. C. Replace timer. D. Replace brine valve seat and clean valve. E. Clean brine line flow control.
8. Softener fails to draw brine.	A. Drain line flow control is plugged. B. Injector is plugged. C. Injector screen plugged. D. Line pressure is too low. E. Internal control leak.	A. Clean drain line flow control. B. Clean injector. C. Clean screen. D. Increase line pressure to 20 P.S.I. E. Change seals, spacers and piston assembly.
9. Control cycles continuously.	A. Broken or shorted switch	A. Determine if switch or timer is faulty and replace it, or replace complete power head.
10. Drain flows continuously.	A. Valve is not programming correctly. B. Foreign material in control. C. Internal control leak.	A. Check timer program and positioning of control. Replace power head assembly if not positioning properly. B. Remove power head assembly, and inspect bore, remove foreign material and check control in various regeneration positions. C. Replace seals and piston assembly.

MODEL 2500 & 1500

Seal and Spacer Replacement

1. Remove electrical plug from outlet, turn off water supply to valve and relieve water pressure.
2. Remove control box cover.
3. Disconnect the brine line, from the injector housing to the brine valve (if your unit has timed brine tank fill).
4. Remove the two capscrews that hold the back plate to the valve.
5. Grasp the back plate on both sides and slowly pull end plug and piston assembly out of the valve body, (see Fig. 1) and lay aside.

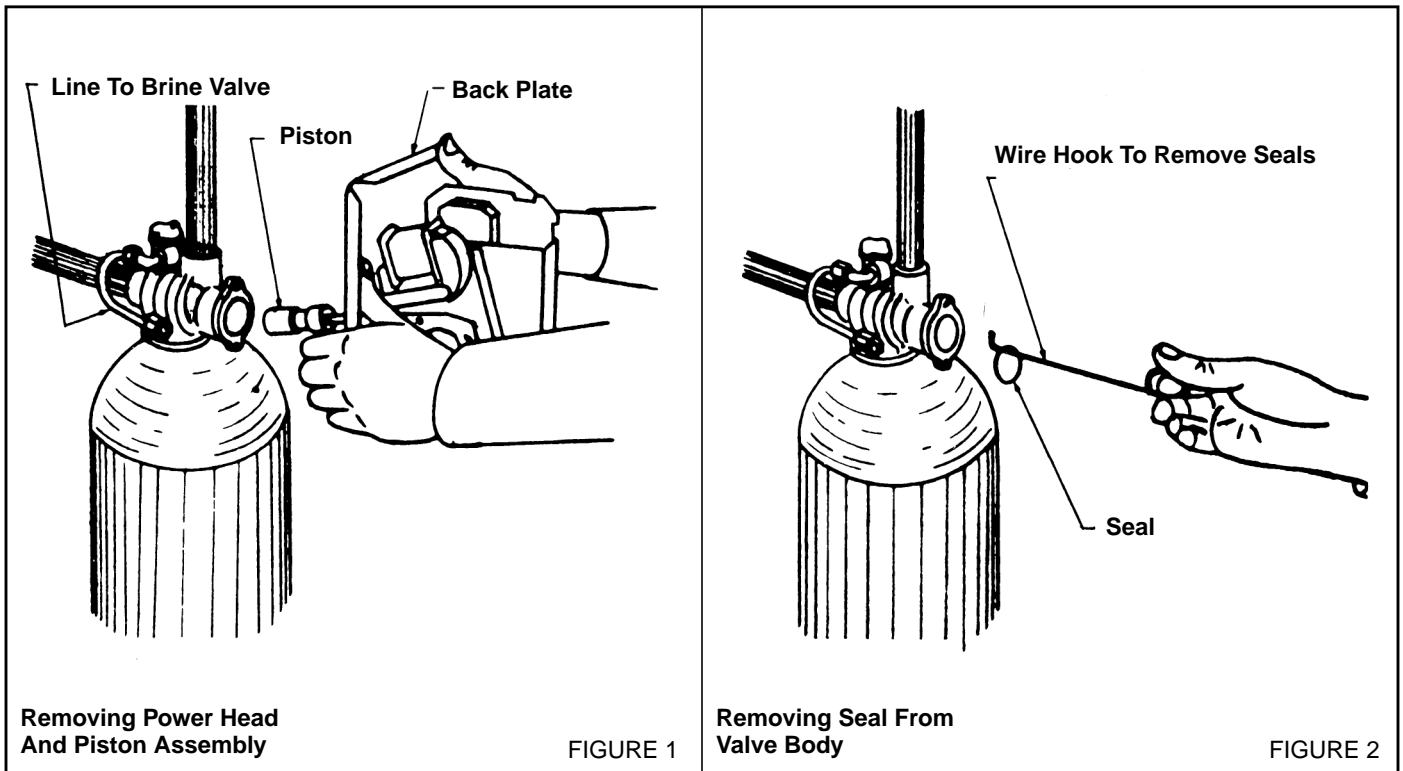

6. Remove the seal first using the wire hook with the finger loop (see Fig. 2).
7. The spacer tool (use only for removing the spacers) has three retractable pins, retained by a rubber ring, at one end; they are retracted or pushed out by pulling or pushing the center button on the opposite end.
8. Insert the pin end of the spacer tool into the valve body with the pins retracted (button pulled back). Push the tool tight against the spacer and push the button in, (see Fig. 3). When the button is pushed in, the pins are pushed out to engage the 1/4 dia. holes in the spacer. Remove the tool from the valve body. The spacer will be on the end. Pull the center button back, the pins will be retracted and the spacer can be removed from the spacer tool.

MODEL 2500 & 1500

Seal and Spacer Replacement (Cont'd.)

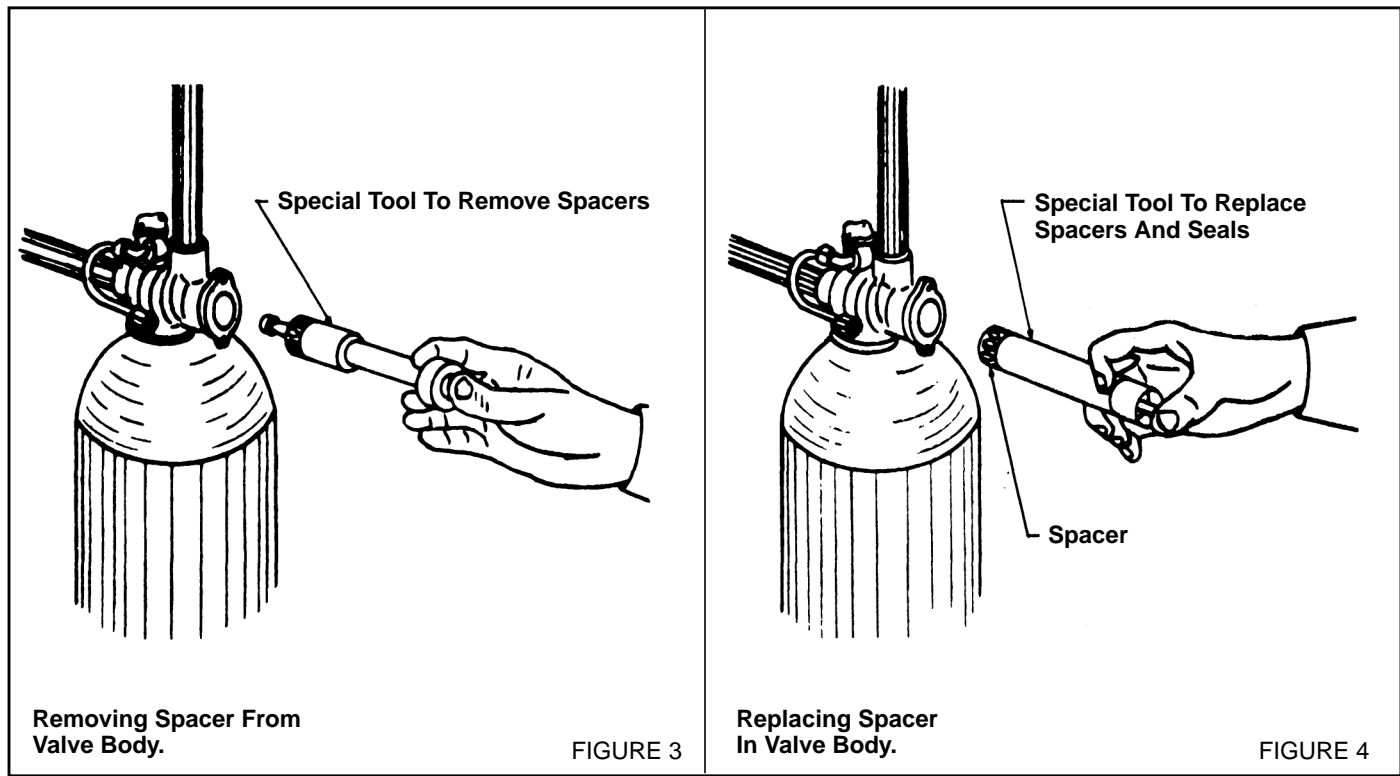

9. Alternately remove the remaining seals and spacers in accordance with steps No. 6 and 8.
10. The last or end spacer does not have any holes for the pins of the spacer tool to engage, therefore if the end spacer does not come out on the first try, try again using the wire hook with the finger loop.
11. To replace seals, spacers and end ring use special tool with the brass sleeve on one end. This is a double-purpose tool. (See Fig. 4.) The male end acts as a pilot to hold the spacers as they are pushed into the valve body and the brass female end is used to insert the seals into the valve body.
12. To restuff a valve body first take the end ring, (the plastic or brass ring without holes), then with your thumb press the button on the brass sleeve end, the large dia. inner portion is now exposed. (See Fig. 4.) Place the end ring on this pilot with the lip on the end ring facing the tool, and push the tool into the valve body bore until it bottoms. While the tool is in the valve body take a seal and press it into the inside diameter of the exposed brass female end. (See Fig. 5.)
13. Remove the tool, turn it end for end and insert it into the valve body bore. While holding the large dia. of the tool, slide it all the way into the valve body bore until it bottoms, then push the center button to push the seal out of the tool and leave it in place in the valve body. (See Fig. 6.)
14. Remove the tool from the valve body and push the center on the brass female end to expose the pilot on the opposite end. Place a spacer on this end and insert the spacer and tool into the valve.

MODEL 2500 & 1500

Seal and Spacer Replacement (Cont'd.)

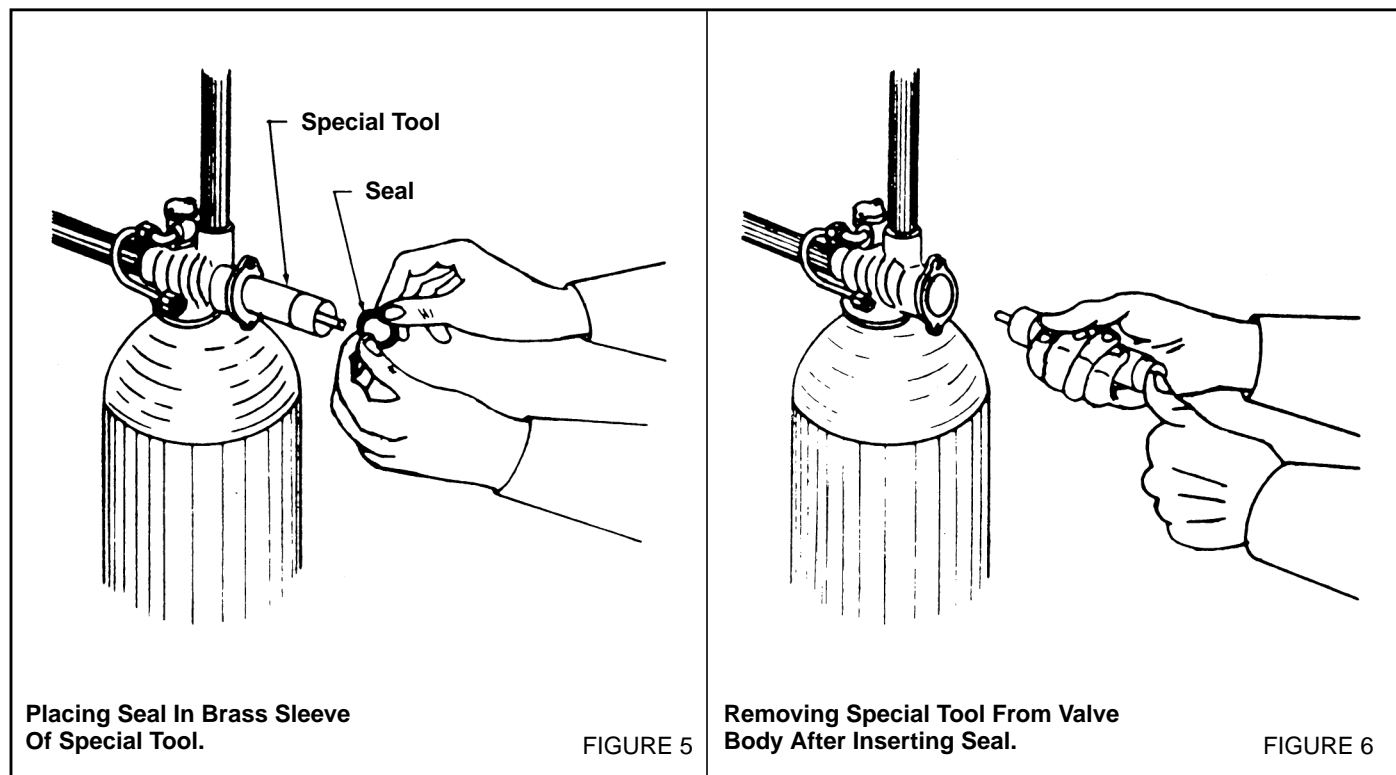

15. While the tool is still in the valve, press another seal into the inside diameter of the exposed brass sleeve end.
16. Remove the tool, turn it end for end, and insert it into the valve body bore.
17. Alternately repeat steps No. 13 and 14 until all seals and spacers have been pushed into the valve. (See valve cross section of your valve.)
18. Place silicone lubricant on the piston and inside the valve.
19. Hold the back plate with one hand and guide the piston into the valve body with the other hand, then grasp the back plate on both sides and slowly push the piston assembly and end plug assembly into the valve. (See Fig. 1.)
20. Replace the two capscews to hold the back plate to the valve and tighten securely.
21. Connect the brine line from the injector housing to the brine valve, (if your unit has timed brine tank fill).
22. Set the time of day dial to the correct time.
23. Replace the electrical plug in the outlet.
24. Turn on water supply.
25. Cycle control and check for proper function.
26. Check by-pass valve.

MODEL 2500 & 1500

Piston Assembly Replacement

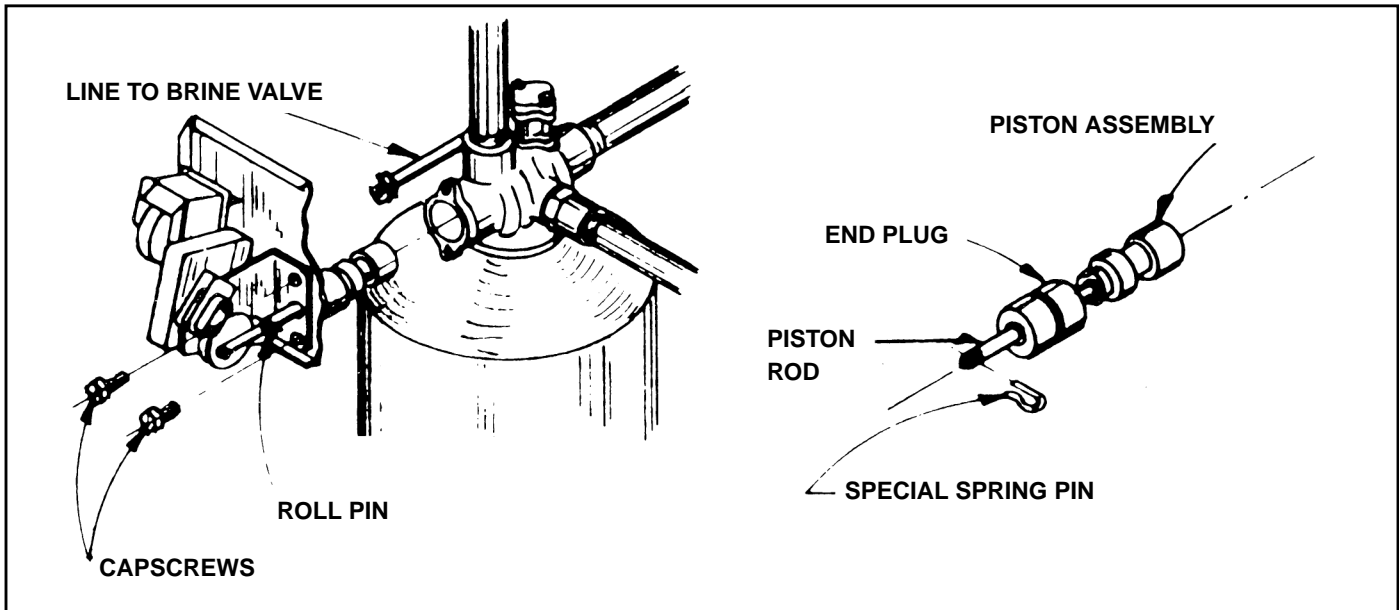

1. Turn off water supply to the valve and relieve water pressure.
2. Cycle the valve until the piston is in the service position (piston rod all the way out).
3. Remove electrical plug from outlet.
4. Remove two capscrews holding back plate to valve.
5. Disconnect brine line, from injector housing to brine valve, at the brine valve (if your unit has timed brine tank fill).
6. Grasp the back plate on both sides and slowly pull end plug and piston assembly out of the valve body.
7. Pull out the roll pin or special spring pin that connects the piston rod to the connecting link and remove the complete end plug and piston assembly.
8. Take the new piston assembly as furnished, pass thru the back plate and motor support and fasten piston rod to the connecting link with special spring pin.
9. Inspect the inside of the valve to make sure that all seals and spacers are in place.
10. Spread or spray silicone lubricant on the piston and on the seals inside the valve body.
11. While holding the back plate on the side with one hand, start the piston into the valve by guiding it with the other hand. Then grasp the back plate on both sides and slowly push the piston and then the end plug into the valve.
12. Replace the two valve body capscrews and tighten.
13. Connect the brine line to the brine valve, if used.
14. Place electrical plug in outlet.
15. Set time of day.
16. Turn on water supply.
17. Cycle control and check for proper function.
18. Make sure that valve is in service position (piston rod all the way out).
19. Check by-pass valve.

MODEL 2500 & 1500

Typical Top Mounting Installation

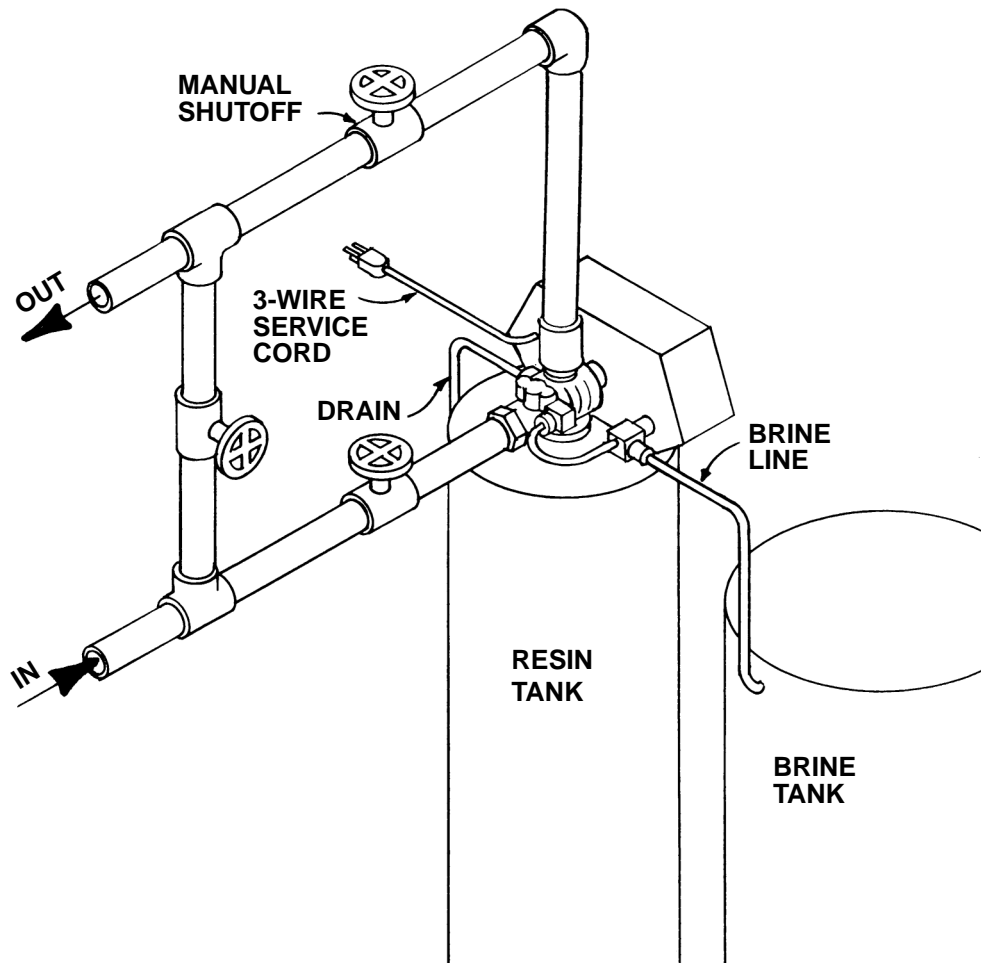

TYPICAL CONTROL VALVE INFORMATION

Tank Size Dia.	Injector	Slow Rinse Rate (gpm) @ 40 PSI	Brine Draw Rate (SPM) @ 40 PSI	B.L.F.C. ¹	D.L.F.C. ²
6"	#0 Red	.31 gpm	.28 gpm	.5 gpm	1.2 gpm
7"		.31 gpm	.28 gpm	.5 gpm	1.2 gpm
8"	#1 White	.45 gpm	.38 gpm	.5 gpm	1.5 gpm
9"		.45 gpm	.38 gpm	.5 gpm	2.0 gpm
10"		.45 gpm	.38 gpm	.5 gpm	2.4 gpm
12"	#2 Blue	.84 gpm	.56 gpm	1.0 gpm	3.5 gpm
13"		.84 gpm	.56 gpm	1.0 gpm	4.0 gpm
14"	#3 Yellow	1.0 gpm	.63 gpm	1.0 gpm	5.0 gpm
16"		1.0 gpm	.63 gpm	1.0 gpm	7.0 gpm

Note: Due to varying water conditions, tank sizes and water pressures, the above settings should be used only as a guideline.

¹B.L.F.C. (Brine Line Flow Control). Refill Rate for Filling Brine Tank.

²D.L.F.C. (Drain Line Flow Control). Backwash and Rapid Rinse Flow Rates.

MODEL 2500 & 1500

Wiring Diagram for Valve Drive Motor and Timer

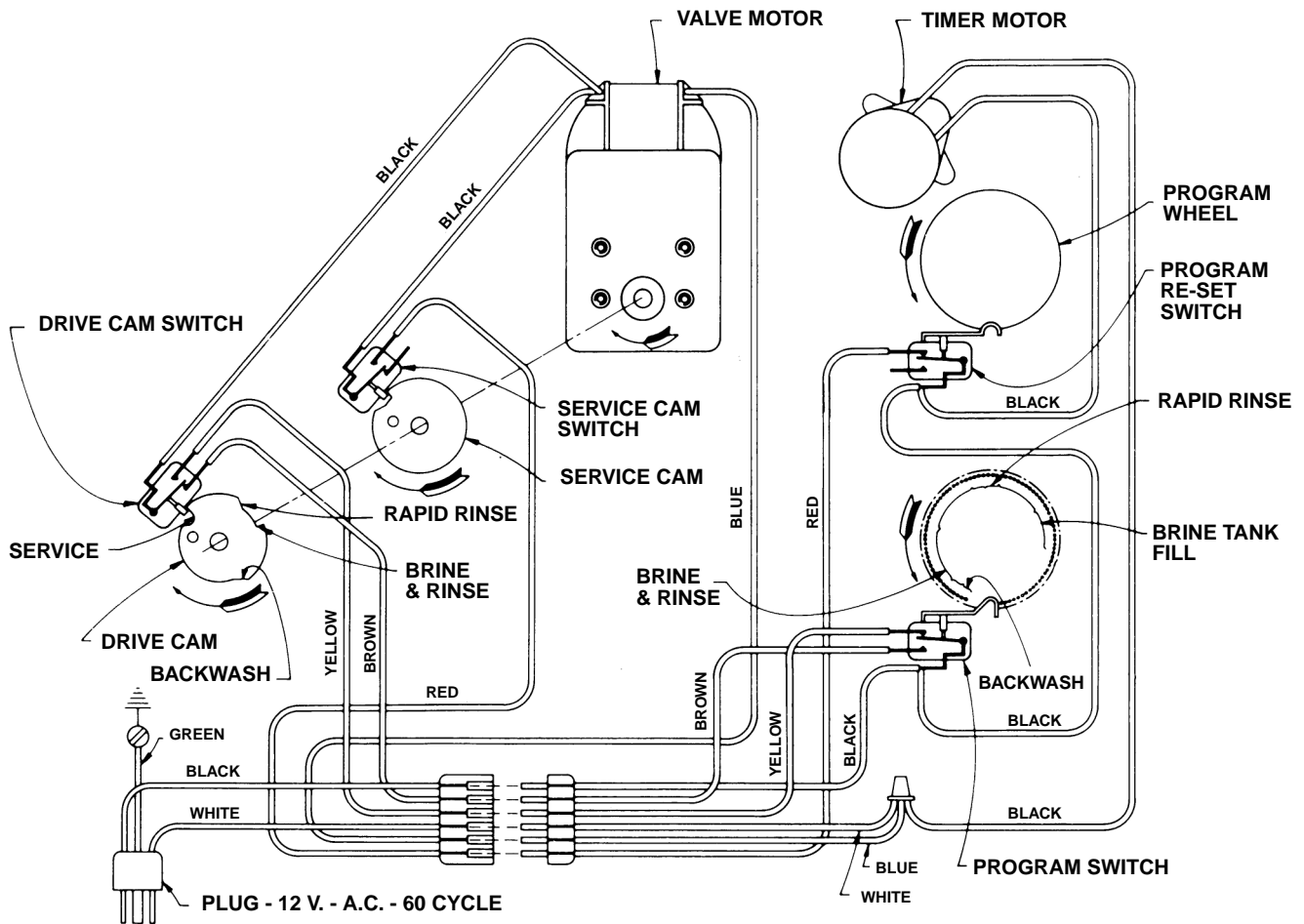

MODEL 2500 & 1500

Service Assemblies

60020-25	BLFC .25 GPM	6.	10545-01	Seal, Piston	
60020-50	BLFC .50 GPM	1.	10757	End Spacer, Noryl	
60020-100	BLFC 1.0 GPM	5.	11451	Spacer, 12 Hole	
	For Illustration, See Page 20				
60029	1600 Brine Valve		60122	Seal and Spacer Kit, Hot Water	
	For Illustration, See Page 20	6.	10545	Seal, Piston, Hot Water	
1	10249	Brine Valve Spring	1.	10757B	End Spacer, Hot Water
1	10250	Retaining Ring	5.	16589	Spacer, Hot Water
2	10329	3/8" Brass Nut			
2	10330	3/8" Ferrule			
2	10332	3/8" Sleeve			
1	11749	B/V Stem Guide			
1	11982	O-Ring Brine Valve			
1	12552	1600 Brine Valve Stem			
1	12626	Shut-Off Valve Seat			
1	12748	Brine Valve Body			
1	12550	Quad Ring			
	60080	1600 Injector Assembly			
		For Illustration, See Page 12 & 14			
1	10227	Injector Screen	2.	10218	Micro Switch
1	11893	Injector Cap	1.	10250	Retaining Ring
1	10229	Injector Cover Gasket	2.	10302	Insulator, Limit Switch
1	10328	90° Elbow 1/4" NPT x 3/8 Tube	2.	10338	Pin, Roll 3/32 x 7/8
2	10692	Screw	1.	10621	Link, 2500
1	10913	Injector Nozzle	1.	10769	Motor, Drive 120V 60HZ
1	10914	Injector Throat	1.	10774	Bracket, Motor Drive Side
1	11475	Injector Body Gasket	5.	10872	Screw, Hex Washer 8-32 x 5/16
1	17776	Injector Body	1.	11667	Wire Harness, Drive Motor
	60090	Piston Assembly	1.	11826	Bracket, Sensor Motor
		For Illustration, See Page 12 & 14	1.	12576	Cam, Drive STE
1	10209	Quad Ring, -010	1.	12777	Cam, Shut-Off Valve
1	10234	O-Ring, -024	1.	13366	Bearing, Drive 2500
1	10598	End Plug Assembly	2.	14923	Screw, Pan HD Mach 4-40 x 1
1	10909	Pin, Link	1.	17904	Bushing, Heyco 1/2
1	15168	Piston 2500			
1	14452	Piston Rod, 2500			
1	14309	Retainer, Piston Rod			
	60091	Piston Assembly, Hot Water			
		For Illustration, See Page 12 & 14			
	60121	Seal and Spacer Kit			

